

Product Information



FORCE 5i Air Winch

Model

FA10i and FA10i-CE

(-CE compliant with European Directives)

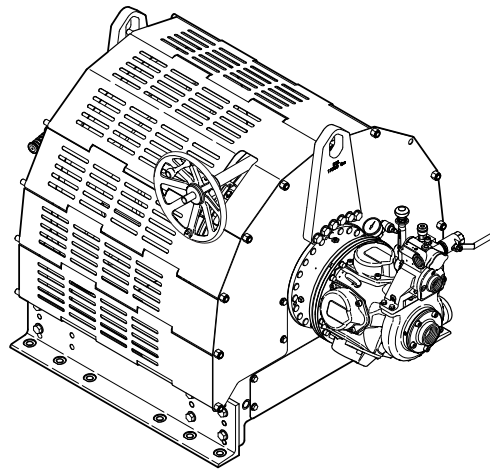

(Dwg. MHP2947)



Save These Instructions



Form MHD56439
Edition 4
February 2016
45899812
© 2016 Ingersoll Rand

Only allow **Ingersoll Rand** trained technicians to perform maintenance on this product. For additional information contact **Ingersoll Rand** factory or nearest Distributor.

For additional supporting documentation refer to Table 1 'Product Information Manuals' on page 2.

Manuals can be downloaded from ingersollrandproducts.com

The use of other than genuine **Ingersoll Rand** replacement parts may result in safety hazards, decreased performance and increased maintenance and will invalidate all warranties.

Original instructions are in English. Other languages are a translation of the original instructions.

Refer all communications to the nearest **Ingersoll Rand** Office or Distributor.

Table 1: Product Information Manuals

Publication	Part/Document Number	Publication	Part/Document Number
Product Safety Information Manual (Non-Man Rider)	MHD56250	Product Maintenance Information Manual	MHD56401
Product Parts Information Manual	MHD56400		

PRODUCT DESCRIPTION

Infinity series winches are air powered, planetary geared units designed for and intended for use as utility winches, with a Mechanism Classification of M5. They shall not be used for lifting or moving personnel. They may be used to pull or lift loads at various wire rope take-off angles. Winches can be equipped, with either an internal automatic disc brake, a manual or automatic band brake, or a combination of both disc and band brake.

The output from an externally mounted piston air motor is transmitted through a coupling and shaft to the planetary reduction gear assembly. Output from the planetary reduction gear assembly is connected to the wire rope drum through the output shaft.

The disc brake assembly consisting of friction plates splined to a hub which in turn is connected to the drive shaft from the air motor. Brake friction plates are clamped to the drum shaft through a spring applied piston. The brake remains applied until the winch control valve is operated and winch pay out or haul-in occurs. Air is introduced into a chamber, which is formed between brake piston and brake housing, causing the brake piston to react, compressing brake springs and releasing friction plates allowing motor shaft to rotate. A power failure or sudden loss of air will immediately cause the spring applied brake to engage. The band brake operates by applying a friction force between brake band and winch drum. The manual band brake requires an operator to rotate a hand wheel located at side of band brake. The automatic band brake operation is similar to disc brake operation; they are both fully disengaged in the haul-in and payout direction.

The design life of the winch is based on the application. Refer to 'Maintenance Intervals' chart in Product Maintenance Information Manual. At the completion of the specified maintenance intervals, the winch should be subjected to a complete inspection by an **Ingersoll Rand** trained technician for determination of remaining service life.

CE winches in addition to the above have drum guard, upper and lower limit switches, overload protection and emergency stop as standard features, and are compliant with CE directives.

SPECIFICATIONS

Model Code Explanation

Example: FA10i-36MK320P

	FA10i	-	36	M	K	320	P	
Series (Capacity):								
FA10i	= 22,000 lbs (10 metric tons)							
Drum Flange Height:								
-	= Standard flange							
Drum Length (Distance between drum flanges):								
36	= Standard (Refer to Table 3 'Specifications' on page 4 for drum lengths)							
Drum Brake:								
A	= Automatic Band Brake							
M	= Manual Band Brake							
X	= None							
Disc Brake:								
K	= Automatic Disc Brake							
X	= None							
Control:								
1	= Winch mounted lever throttle (Standard)							
* 2XX	= Remote full flow lever throttle [XX = Specify hose length (feet). Maximum 20 ft. (6 metres)]							
* 3XX	= Remote pilot pendant throttle [XX = Specify hose length (feet). Maximum 66 ft. (20 metres)]							
* 4XX	= Remote pilot lever throttle [XX = Specify length (feet). Maximum 66 ft. (20 metres)]							
* 5XXX	= Remote electric over air throttle †							
Options: **								
7	= Drum Grooving (Number = wire rope size in sixteenths, e.g. 7/16 inch) †							
B	= Extended Warranty							
** CM	= Low Temperature Components; C1M3 = -20° ABS, C2M3 = -20° DNV							
D	= Drum Divider Flange and additional wire rope anchor †							
E	= Construction Cage †							
G	= Drum Guard							
J	= Air Line Accessories (not mounted to winch)							
L	= Drum Locking Pin							
** M1	= Material Traceability (typical material results) ††							
** M2	= Material Traceability (actual material results) ††							
** M3	= Material Traceability (actual material results for these parts in finished, as-delivered condition) ††							
N4	= American Bureau of Shipping (ABS)							
N5	= Det Norske Veritas (DNV)							
P	= Marine 812 Grade Corrosion Preventative Finish							
P1	= Marine 812-X Grade Corrosion Preventative Finish							
Q	= Adjustable Accu-Spool™ (refer to MHD56390) †							
S	= Limit Switch (upper and lower)							
U	= Underwound							
V	= Press Roller							
-CE	= Compliance with European Machinery Directive and EN 14492-1							
				W1	= ABS witness test			
				W2	= DNV witness test			
				W3	= LRS witness test			
				W4	= Customer witness test			
				Y	= Overload protection with emergency stop on lever throttle valve			

Notes:

- * Remote throttles are provided with 6 feet (2 metres) of hose. Specify hose lengths greater than 6 feet. For lengths greater than 20 feet (6 metres) with the remote full flow throttle, or 66 feet (20 metres) with the remote pilot lever and remote pilot pendant throttles, contact your **Ingersoll Rand** distributor or the factory for control acceptability. Metric lengths are provided for reference only, order lengths in feet.
- ** Documentation, witness testing and material traceability available; must be requested at time of order. Specify options or contact the factory or your nearest **Ingersoll Rand** distributor for information.
- † Not covered in this manual.
- †† Refer to 'Traceability' on page 4 for a description of the differences between M1, M2 and M3.

All -E models are manufactured to previous European Machinery directives. Refer to Data (Name) Plate on winch to determine model. If winch is a custom build also refer to the Declaration of Conformity for serial number break.

Table 2: Specifications

Models	Air System			Rated Performance (at rated pressure/volume)										
	Rated Operating Pressure	Air Consumption (at rated pressure and load)		Full Drum Line Pull		Full Drum Line Speed		Max Stall Pull, First Layer		Force Limit Factor	Maximum Freeboard		Net Weight **	
		scfm	cu.m/min	Lbs	Kgs	fpm	m/min	lbs	kgs		inch	mm	lbs	kgs
FA10i	90 psig (630 kPa / 6.3 bar)	800	22.7	22000	10000	23	7	52650	23880	N/A	1/2	13	3500	1588
FA10i-CE										1.6	2.2	56	3720	1687

** Weight of standard winch without wire rope

Table 3: Specifications

Models	Drum Barrel Size		Drum Flange Diameter		Recommended Wire Rope Size		Sound Pressure Level	Sound Power Level	Maximum Foundation Anchor Shear Force At One Capscrew		Air Motor Pipe Inlet Size		Minimum Air System Hose Size (inside diameter)	
	inch	mm	inch	mm	inch	mm			Lbs	N	inch	mm	inch	mm
	FA10i & FA10i-CE	20	508	38	965	1-1/8			28	101	113	3655	16260	1.25

Sound measurements have been made in accordance with ISO 11201, ISO 3744-3746 and ISO 4871 test specifications for sound from pneumatic equipment. Readings shown are based on the average noise level of each winch configuration, proportionate to the utilized time in a regular cycle.

Lpc (Peak Sound Pressure) does not exceed 130 dB. Performance based on 90 psig (6.3 bar/630 kPs) operating pressure.

NOTICE

- All -E winch models are manufactured to previous European Machinery directives. Refer to Data (Name) Plate on winch to determine model. If winch is a custom build also refer to the Declaration of Conformity for serial number break.

Traceability

Load bearing parts are documented to provide traceability. Documentation includes chemical and physical properties of raw material, heat treating, hardening, tensile and charpy tests as required for the part.

Units with M1, M2 or M3 in the model code have traceable load bearing components.

M1 – Material Traceability certificates according to EN 10204 (Ex DIN 50049) 2.2 on load bearing parts. Conformity documents affirm (by the manufacturer) that parts are in compliance with requirements of the order, based on non-specific inspection and testing (i.e. results are typical material properties for these parts).

M2 – Material Traceability certificates according to EN 10204 (Ex DIN 50049) 3.1b on load bearing parts. Conformity documents affirm (by a department independent of the manufacturing department) that actual parts are in compliance with requirements of the order, based on specific inspection and testing (i.e. results are actual material properties for these parts).

M3 – Material Traceability certificates according to EN 10204 (Ex DIN 50049) 3.1b on load bearing parts. Conformity documents affirm (by a department independent of the manufacturing department) that the actual parts used in the product are in compliance with the order, based on specific inspection and testing (i.e. results are actual material properties for these parts in a finished, as delivered condition).

Components with part numbers ending in CH are charpy parts for use under extreme cold conditions. Traceability requirements must be stated when reordering these parts for continued certification.

ATEX

Refer to labeling on product, located near or on data (name) plate, for specific ATEX designation. Product not marked as such, are not suitable for use in any potentially explosive atmosphere (ATEX). Refer to Product Safety and Maintenance Information Manuals for further explanation.



(Dwg. MHP2584)

INSTALLATION

Prior to installing the product, carefully inspect it for possible shipping damage. Products are supplied fully lubricated from the factory. Check oil levels and adjust as necessary before operating product. Refer to "LUBRICATION" section on page 8 for recommended oils and lubrication intervals.

WARNING

- Product not installed properly may fall or cause a load to fall resulting in severe injury or death. Before installation and operation of this product refer to Product Safety Information manual and all safety warnings pertaining to this product.

CAUTION

- Always install, operate, inspect, and maintain this product in accordance with all applicable standards and regulations (state, country, and federal, etc.). For example In the USA, the applicable standards are American Society of Mechanical Engineers (ASME) and National Fire Protection Agency (NFPA).

Mounting

Care must be taken when moving, positioning or mounting the winch. In most cases, lifting lugs have been provided to assist in handling the winch. If lug locations are improper for your specific installation, great care should be taken to ensure that winch, when lifted, will be properly balanced. Determine weight of your winch by referring to "SPECIFICATIONS" section on page 3. Add weight of wire rope and other installed options as necessary. Lift winch 3 to 4 inches (75 to 100 mm) off ground. Verify winch is balanced and secure before continuing lift. Mount winch so axis of drum is horizontal and that motor vent cap is not more than 15° off top vertical center. If winch is to be mounted in an inverted position, motor case must be rotated to position vent cap to the top.

- The winch mounting surface must be flat and of sufficient strength to handle rated load plus weight of winch and attached equipment. An inadequate foundation may cause distortion or twisting of winch uprights and siderails resulting in winch damage.
- Make sure mounting surface is flat to within 0.005 inch (0.127 mm) per inch of drum length. Shim if necessary. Refer to Table 4 'Mounting Surface Tolerance' on page 4.
- Mounting bolts must be Grade 8 or better. Use self-locking nuts or nuts with lockwashers. Refer to Table 5 'Mounting Bolts' on page 4.
- Tighten mounting bolts evenly and torque to specification in torque chart. Refer to "TORQUE CHART" in Product Maintenance Manual.
- Maintain a fleet angle between sheave and winch of no more than 1-1/2°. The lead sheave must be on a center line with drum and, for every inch (25 mm) of drum length, be at least 1.6 feet (0.5 metre) from the drum. Refer to Product Safety Information Manual.

- Do not weld to any part of winch.

Table 4: Mounting Surface Tolerance

Drum Length		Mounting Surface Minimum Flatness	
inch	mm	inch	mm
24	610	0.12	3.05
30	762	0.15	3.81
36	914	0.18	4.57
40	1016	0.20	5.08
50	1270	0.25	6.35

Table 5: Mounting Bolts

Model	Mounting Bolts	
	inch	mm
FA10i	7/8	22

Refer to Dwg. MHP0920 on page 10, A. Drum.

Table 6: Winch Bolt Hole Mounting Dimensions

Dimension		Drum Length (inches)				
		24	30	36	40	50
"A"	inch	42.25				
	mm	1073				
"B"	inch	6	8			
	mm	152	203			
"C"	inch	15/16				
	mm	24				
"D" (With Band Brake)	inch	14	12	18	22	32
	mm	356	305	457	559	813
"D" (Without Band Brake)	inch	10	8	14	18	28
	mm	254	203	356	457	711

■ Wire Rope

CAUTION

- Maintain at least 3 tight wraps of wire rope on the drum at all times.
- Do not use wire rope as a ground (earth) for welding.
- Do not attach a welding electrode to winch or wire rope.
- Install wire rope to come off drum for overwind operation (normal application).

NOTICE

- For horizontal applications order the "H" option or contact factory prior to operation.

■ Wire Rope Selection

Consult a reputable wire rope manufacturer or distributor for assistance in selecting the appropriate type and size of wire rope and, where necessary, a protective coating. Use a wire rope which provides an adequate safety factor to handle the actual working load and meets all applicable industry, trade association, federal, state and local regulations.

When considering wire rope requirements the actual working load must include not only the static or dead load but also loads resulting from acceleration, retardation and shock load. Consideration must also be given to the size of the winch wire rope drum, sheaves and method of reeving. Maximum wire rope diameter is limited by the wire rope anchor. It is recommended that wire rope construction be 6 X 19 or 6 X 37 IWRC right lay. Refer to Table 7 'Minimum and Maximum Wire Rope Size' on page 5 for recommended sizes.

Table 7: Minimum and Maximum Wire Rope Size

Model	Minimum		Maximum	
	inch	mm	inch	mm
FA10i	3/4	20	1- 1/8	28

Note 1: Maximum wire rope diameter is limited by size of wire rope anchor hole. Refer to Product Parts Information Manual for correct wire rope anchor part numbers.

Note 2: Wire rope diameter is fixed if grooved drum option is used.

■ Installing Wire Rope

NOTICE

- When installing wire rope, pressurize disc brake with a minimum of 45 psi (3.1 bar) air from an auxiliary source.

Refer to Dwg. MHP2686 on page 10, **A.** Anchor; **B.** Wire Rope.

1. Cut wire rope to length in accordance with wire rope manufacturer's instructions.
2. Feed end of wire rope through drum anchor pocket hole.
3. Forming a loop, wrap loop around anchor, approximately 22 inches (559 mm) of wire rope.
4. Pull wire rope anchor into position in drum anchor pocket. Ensure no extra (open end) of wire rope is extending out of drum anchor pocket.

CAUTION

- Make sure first wrap of wire rope is tight and lays flush against drum flange.

■ Safe Wire Rope Handling Procedure

- Always use gloves when handling wire rope.
- Never use wire rope that is frayed or kinked.
- Never use wire rope as a sling.
- Always make sure wire rope is correctly spooled and the first layer is tight against drum.
- Always follow wire rope manufacturer's recommendation on use and maintenance of wire rope.

■ Wire Rope Spooling

To compensate for uneven spooling and the decrease in line pull capacity as the drum fills up, use as short a wire rope as practical. When rewinding apply tension to the end of the wire rope to eliminate line slack. This helps achieve level winding and tight spooling.

■ Rigging

Make sure all wire rope blocks, tackle and fasteners have a sufficient safety margin to handle required load under all conditions. Do not allow wire rope to contact sharp edges or make sharp bends which will cause damage to wire rope, use a sheave. Refer to wire rope manufacturer's instructions for proper sizing, use and care of wire rope.

■ Safe Installation Procedures

1. Do not use wire rope as a ground (earth) for welding.
2. Do not attach a welding electrode to winch or wire rope.
3. Never run wire rope over a sharp edge. Use a correctly sized sheave.

4. When a lead sheave is used, it must be aligned with center of drum. The diameter of lead sheave must be at least 18 times the diameter of wire rope. Refer to Dwg. MHP2449 in Product Safety Information manual.
5. Always maintain at least three full, tight wraps of wire rope on drum.

■ Drum Guard

Use of a drum guard is recommended on all winches, and is standard on -CE winches. Refer to the Product Parts Information Manual.

Drum guard panels must be adjusted to suit wire rope departure angle. To reposition drum guard panels remove nuts and slide out crossbar. Position panels to avoid wire rope contact and install crossbar and nuts.

WARNING

- Do not allow wire rope to come in contact with drum guard panels during winch operation. Wire rope could become worn and damaged. Adjust drum guard panels to clear wire rope travel angle.

■ Air Supply

The air supply must be clean, free from moisture and lubricated to ensure optimum motor performance. Foreign particles, moisture and lack of lubrication are the primary causes of premature motor wear and breakdown. Using an air filter, lubricator and moisture separator will improve overall product performance and reduce unscheduled downtime. Refer to Dwg. MHP0191 on page 10, **A.** Air Out; **B.** Lubricator; **C.** Regulator; **D.** Air In; **E.** Filter.

Refer to Table 2 'Specifications' on page 3 for motor air consumption and rated operating pressure. If air supply varies from what is recommended, product performance will change.

Install air line lubricator, filter and regulator as close as possible to air inlet on motor. Lubricator must be located no more than 10 ft (3 m) from motor. Air line accessories package can also be mounted to the winch guard panel on the operator's side or opposite.

■ Air Lines

Inside diameter of air supply lines must not be less than size specified in Table 2 'Specifications' on page 3. Before making final connections, all air supply lines should be purged with clean, moisture free air or nitrogen before connecting to main air inlet. Supply lines should be as short and straight as installation conditions will permit. Long transmission lines and excessive use of fittings, elbows, tees, globe valves, etc. cause a reduction in pressure due to restrictions and surface friction in lines.

■ Air Line Lubricator

Always use an air line lubricator with these motors. The lubricator must have an inlet and outlet at least as large as inlet on motor.

CAUTION

- Lubricator must be located no more than 10 ft (3 m) from motor.
- Shut off air supply before filling air line lubricator.

The air line lubricator should be replenished daily and set to provide 2 to 3 drops per minute of ISO VG 32 (SAE 10W) oil. A fine mist will be exhausted from control valve when air line lubricator is functioning properly.

■ Air Line Filter

It is recommended that an air line strainer/filter be installed before the lubricator to prevent dirt from entering the motor. The strainer/filter should provide 20 micron filtration and include a moisture trap. Clean the strainer/filter periodically to maintain its operating efficiency.

NOTICE

- When air filter is used ensure it allows air to pass through at products rated scfm. Refer to "SPECIFICATIONS" on page 3.

■ Air Pressure Regulator

If an air pressure regulator is used, install between lubricator and filter.

NOTICE

- Do not adjust regulator for a CE marked product, these are preset at factory and pressure gauges are not provided. Adjustment of regulator will effect overload settings and product will no longer conform to CE regulations.
- Not all products are CE approved, refer to products data (name) plate to see if this applies.

■ Moisture in Air Lines

Moisture that reaches the air motor through air supply lines is a primary factor in determining the length of time between service overhauls. Moisture traps can help to eliminate moisture. Other methods, such as an air receiver which collects moisture before it reaches motor, or an aftercooler at compressor that cools air to condense and collect moisture prior to distribution through supply lines, are also helpful.

■ Mufflers

Ensure mufflers are installed in winch exhaust manifold and control valve exhaust port. Check mufflers periodically to ensure they are functioning correctly.

■ Shut Off Valve

Refer to the Product Safety Information Manual for information.

■ Motor

For optimum performance and maximum durability of parts, provide recommended air supply as measured at motor inlet. Refer to Table 2 'Specifications' on page 3. The air motor should be installed as near as possible to compressor or air receiver.

■ Limit Switches

Limit switches are standard on **-CE** winches.

Pre-set limit switch settings prevent winch wire rope payout and haul-in by stopping air flow to the winch motor when a defined set point has been reached. It is the owner's and operator's responsibility to adjust winch operating limits prior to using winch.

NOTICE

- **Settings for limit switch are for an overwound operation only.**

To adjust set points:

Follow instructions in the order they appear for limit switch adjustment (**use two people to make adjustments**). Refer to Dwg. MHP2688 on page 10, **A.** Center Nut; **B.** Payout; **C.** Haul-In:

1. Remove cap from limit switch cover.
2. Partially unscrew center nut.
3. **PAYOUT:** Rotate (#1) screw (counterclockwise) while slowly paying out until winch shuts off.
4. **HAUL-IN:** Rotate (#2) screw (clockwise) while slowly hauling in until winch shuts off.
5. Tighten center nut.
6. Reinstall cap on limit switch cover and tighten.

⚠ WARNING

- **Ensure limit switch setpoints are established and operating properly before putting winch into service.**

■ Press Roller

Ensure wire rope is positioned between press roller and drum barrel and springs keep press roller in tight contact with wire rope.

■ Initial Winch Operating Checks

Winches are tested for proper operation prior to leaving the factory. Before the winch is placed into service the following initial operating checks should be performed.

1. When first running the motor inject a small amount of light oil into the inlet connection to provide initial lubrication.
2. Check oil level in motor, reduction gear assembly and disc brake are correct. Top off levels as required before operation as described in "LUBRICATION" on page 8.
3. Operate winch in both directions with no load for one to two minutes.
4. New brake band Lining Run-in Procedure: All new brake band linings require a 'run-in' period. Operate the winch without load in the payout direction while gradually applying the brake. Allow the brake to slip for approximately one minute. Winch motor may stall as drum brake band lining fully engages. Do not allow brake to overheat.
5. Check operation of brakes. Adjust if necessary as described in "MAINTENANCE" section in the Product Maintenance Information Manual.
6. Check operation of limit switches, locking mechanisms and all safety devices when equipped.
7. Check foundation mounting fasteners are secure.
8. Install drum guard when provided.

For winches that have been in storage, the following start-up procedures are required:

1. Give the winch an inspection conforming to requirements of 'Winches Not in Regular Use' on page 8.
2. Pour a small amount of ISO VG 32 (SAE 10W) oil in motor inlet port.
3. Operate motor for 15 seconds in both directions to flush out any impurities.
4. The winch is now ready for normal use.

OPERATION

It is recommended that the user and owner check all appropriate and applicable regulations before placing this product into use. Refer to Product Safety Information Manual before operating product.

The four most important aspects of product operation are:

1. Follow all safety instructions when operating the product.
2. Allow only people trained in safety and operation of this winch to operate this equipment.
3. Subject each product to a regular inspection and maintenance procedure.
4. Be aware of product capacity and weight of load at all times.

⚠ WARNING

- **Do not lift loads over people.**

NOTICE

- **Refer to Product Parts Information Manual for drawings unless specified elsewhere.**

■ Winch Controls

The spring loaded, motor mounted, live air manual throttle control valve is supplied as a standard feature on this winch. Optional remote throttle controls are available. Reference model code on the winch data (name) plate and compare it to "SPECIFICATIONS" on page 3, to determine your configuration. The throttle controls provide operator control of motor speed and direction of drum rotation.

■ Winch Mounted Air Throttle

Refer to Dwg. MHP1809 on page 10, **A.** Haul-In; **B.** Exhaust Port; **C.** Lift Slider Handle UP to Unlock; **D.** Payout; **E.** Air Inlet Port; **F.** Brake Release Port.

The winch control throttle valve is spring loaded, full flow air and mounts to the motor rotary housing.

To operate control valve, place palm of hand on control knob and wrap fingers around flange of sliding handle. Squeeze fingers, lifting sliding handle up to unlock control handle. Shift control handle in desired direction to payout or haul-in wire rope. As viewed from air motor end, move control throttle handle to the right (clockwise) to payout wire rope and to the left (counterclockwise) to haul-in wire rope. Avoid sudden movements of handle to ensure smooth operation of winch. When released, handle will return to neutral or center position, sliding handle will drop down to engage and lock control handle in place.

■ Remote Full Flow Air Throttle

Refer to Dwg. MHP2043 on page 11, **A.** To Brake; **B.** Threaded Ports.

Provides for remote mounting of winch control at a fixed location at up to 20 feet (6 metres) away from winch motor. Air hoses connect throttle to winch motor to provide winch operation.

Move control throttle handle to the right (clockwise) to payout wire rope and to the left (counterclockwise) to haul-in wire rope. Avoid sudden movements of control valve to ensure smooth operation of winch.

■ Remote Pilot Pendant Throttle

Refer to Dwg. MHP2398 on page 11, **A.** Red - Air Supply; **B.** Green; **C.** Yellow; **D.** Payout load; **E.** Haul-In Load.

Provides for remote winch control at distances of up to 66* feet (20 metres) away from winch. The pilot pendant control throttle is a two function movable control station for winch operation. Pilot pressure from pendant control activates winch control valve. The winch control valve, located on winch motor, controls motor speed and direction of drum rotation. Direction of drum rotation is determined by the pendant lever/button depressed.

■ Remote Pilot Lever Throttle

Provides for remote winch control at distances of up to 66* feet (20 metres) away from winch. The lever pilot control throttle is a fixed mounted lever control station for winch operation. Pilot pressure from lever pilot control throttle activates winch control valve. The winch control valve, located on winch motor, controls motor speed and direction of drum rotation. Direction of drum rotation is determined by the direction in which lever is shifted.

* For distances greater than 50 feet (15 metres) contact **Ingersoll Rand** Technical Sales for control suitability.

■ Underwound Operation (optional feature)

Underwound operation allows wire rope haul-in or payout off the bottom of drum. This is a special operation and requires a winch specifically designed for this usage.

■ Emergency Stop and Overload System

Emergency Stop and Overload System are standard on **-CE** winches.

Refer to Dwg. MHP2619 on page 10, **A.** Emergency Stop Button; **B.** Push Down to Stop Winch Movement; **C.** Overload Valve Reset Button; **D.** Twist Red Button to Reset; **E.** Overload Valve Adjustment Screw.

When emergency stop or overload valve is activated, winch drum rotation will immediately cease.

 **CAUTION**

- **If winch continues to move (payout load) after emergency stop activates, brake(s) are not holding load and may require adjustment or repair.**

When control valve senses a preset pressure difference between ports, a pilot signal is sent to stop flow of air, winch drum rotation will immediately cease.

■ **Emergency Stop**

Emergency stop device is located on the control valve. When activated, winch drum rotation will immediately cease. To activate emergency stop, depress (push down) red palm valve, located on top of control valve.

NOTICE

- **If winch overload occurs, overload device, if equipped, also stops winch. To operate winch after an overload, reduce load and reset overload.**

Emergency Stop Reset:

1. Rotate red stop button, in (counterclockwise) direction until red stop button 'pops' up.
2. Winch is ready to resume operation.

Pendant Control:

Refer to "Emergency Stop" section and Dwg. MHP1892 on page 11, **A.** Pendant Handle; **B.** "Emergency Stop" Button; **C.** "ON" Button; **D.** Winch Control Levers.

■ **Overload System (CE Models only)**

The winch utilizes a direct acting load limiter to limit the maximum line pull to 160% of the rated line pull. The limiter is a pressure regulator that limits the supply air to a pressure that will not allow the winch to pull beyond 160% of the rated line pull.

Checking Overload Valve Setting:

Proper test and adjustment of overload should only be performed by an **Ingersoll Rand** trained technician. The winch shall not be able to lift a load greater than 160% of the rated utility load. If this is possible, adjustment is required.

1. Attach load line to a load that is calibrated to maximum rated load for winch.
2. Move control lever to haul-in position. If winch does not lift load, adjust the adjustment screw. Refer to 'Overload Valve Adjustment' in the Product Maintenance Information Manual.

Setting the Overload:

Attach load line to a load that is calibrated to 160% of winch rated capacity. Shift control lever to haul-in position.

1. If overload valve activates, reset overload valve. Winch is ready for normal operation.
2. If winch lifts higher than 160% of rated load, lower load. Turn jam nut (counterclockwise) in 1/4 turn increments until overload valve activates when control lever is shifted to haul-in position. After each 1/4 turn, retest winch.

■ **Winch Brakes**

■ **Manual Drum Band Brake (optional feature)**

Manual band brake may be applied by turning brake handwheel (104) to the right (clockwise) and released by turning handwheel to the left (counterclockwise). Brake must be kept properly adjusted to hold the required load. Refer to 'Adjustments' in "MAINTENANCE" section in Product Maintenance Information Manual for instructions.

■ **Automatic Drum Band Brake (standard)**

The automatic drum band brake is a spring applied, air released brake which utilizes an air actuated, spring loaded cylinder, that automatically disengages brake when motor is operated. Air pressure in cylinder overcomes spring pressure to release brake. When control valve is placed in neutral position, air in cylinder is vented and spring automatically engages brake to prevent band rotation.

INSPECTION

Inspection information is based in part on American Society of Mechanical Engineers Safety Codes (ASME B30.7).

 **WARNING**

- **All new or repaired equipment should be inspected and tested by Ingersoll Rand trained Service Technicians to ensure safe operation at rated specifications before placing equipment in service.**
- **Never use a winch that inspection indicates is damaged.**

Frequent and periodic inspections should be performed on equipment in regular service. Frequent inspections are visual examinations performed by operators or **Ingersoll Rand** trained Inspectors and include observations made during routine equipment operation. Periodic inspections are thorough inspections conducted by **Ingersoll Rand** trained Service Technicians. ASME B30.7 states inspection intervals depend upon the nature of the critical components of the equipment and the severity of usage. Refer to "Inspection Classifications" chart and "Maintenance Intervals" chart in Product Maintenance Information Manual for recommended maintenance intervals.

Careful inspection on a regular basis will reveal potentially dangerous conditions while still in the early stages, allowing corrective action to be taken before the condition becomes dangerous.

The cylinder clevis must be kept properly adjusted to hold required load.

NOTICE

- **Extended exposure to corrosive atmospheres can cause the band brake lining to adhere to the drum. It is recommended when winch is not in operation and in a no load condition that the band brake be left in a released position.**

■ **Automatic Disc Brake**

The automatic disc brake is a spring applied, air released brake. Using an air actuated, spring loaded piston, the brake automatically disengages when motor is operated and engages when throttle is returned to neutral position.

Air pressure ported through brake housing overcomes spring pressure and moves piston which releases brake. When control valve is placed in neutral position, air is vented, spring pressure overcomes air pressure and spring pressure moves piston, engages brake and prevents drum rotation.

■ **Drum Locking Pin (optional feature)**

Refer to Dwg. MHP2772 on page 11, **A.** Drum Lock Assembly; **B.** Engaged; **C.** Disengaged.

The drum locking pin assembly is mounted on the outboard upright, opposite motor. Handle movement must be parallel to the winch base. It should be engaged if a load is left suspended. The word "TOP" is stamped into the handle for correct orientation and must be visible from above.

To engage Drum Locking Pin:

When facing the handle, pull handle away from the outboard upright and pivot it to the left. Handle pivot capscrew will be in closest position to drum flange. Operate winch very slowly until locking pin engages one of the drum flange holes.

 **WARNING**

- **Ensure that all braking mechanisms are engaged and all personnel are clear of winch load and rigging before disengaging locking pin.**
- **Extremely difficult locking pin release is an indication that load is held by locking pin and braking mechanisms are not functioning properly. Do not release locking pin until load control is established.**

To disengage Drum Locking Pin:

When facing the handle, pull handle away from the outboard upright and pivot it to the right. Handle pivot capscrew will be in furthest position from drum flange.

■ **Limit Switches**

Limit switches are standard on -CE winches.

Pre-set limit switch settings prevent winch wire rope payout and haul-in by stopping air flow to the winch motor when a set point has been reached. It is the owner's and operator's responsibility to adjust winch operating limits prior to using the winch. To adjust the limit switch set points, refer to 'Limit Switches' on page 6.

Deficiencies revealed through inspection, or noted during operation, must be reported to designated personnel to ensure corrective action is taken.

A determination as to whether a condition constitutes a safety hazard(s) must be decided, and the correction of noted safety hazard(s) accomplished and documented by written report before placing the equipment in service.

■ **Wire Rope Reports**

Records should be maintained as part of a long-term wire rope inspection program. Records should include the condition of wire rope removed from service. Accurate records will establish a relationship between visual observations noted during frequent inspections and the actual condition of wire rope as determined by periodic inspections.



WARNING

Frequent Inspection

On equipment in regular service, frequent inspections should be made by operators at the beginning of each shift. In addition, visual and audible inspections should be conducted during regular operation for indications of damage or evidence of malfunction (such as abnormal noises).

Disassembly may be required as a result of frequent inspection findings or in order to properly inspect the individual components. Disassembly steps are described in the Product Maintenance Information Manual.

- Surrounding Area.** Visually check for winch oil leaks. Do not operate winch if leaking oil is found. Ensure surrounding area has no slippery surfaces and is obstruction free.
- Hoses and Fittings.** Visually inspect for damage, air leaks and loose connections. Repair all leaks or damage and tighten loose connections prior to starting daily tasks.
- Muffler.** Visually check for restrictions or external damage. Clear restrictions or replace if damaged.
- Manual Shut-Off Valve.** Test shut-off valve to ensure proper operation and free movement.
- Guards.** Verify wire rope does not contact guard during winch operation and that guards are secure and undamaged.
- Winch.** Visually inspect winch housings, control(s), external brake, siderails and drum for damage. Check that all external bolts are in place and secure. Report damage to supervisor and request additional inspection by an **Ingersoll Rand** trained Service Technician.
- Winch Operation.** Power winch in both directions. Winch must operate smoothly without sticking, binding or abnormal noises and have minimal vibration.
- Pendant (optional feature).** Ensure operation of pendant levers is smooth and winch is responsive to pendant control. Pendant levers must spring return to the neutral position when released.
- Manual Throttle Lever.** Ensure operation of manual throttle lever is smooth and winch is responsive to lever movement. Lever must return to neutral and lock in place when released. If winch responds slowly or controls stick, do not operate winch until all problems have been corrected.
- Wire Rope.** Visually inspect all wire rope expected to be in use during the day's operations. Inspect for wear and damage indicated by distortion of wire rope such as kinking, "birdcaging," core protrusion, main strand displacement, corrosion, broken or cut strands. If damage is evident, do not operate winch until the discrepancies have been reviewed and inspected further by personnel knowledgeable on wire rope safety and maintenance procedures.

NOTICE

- The full extent of wire rope wear cannot be determined by visual inspection. At any indication of wear inspect wire rope in accordance with instructions in "Periodic Inspection." Refer to Product Maintenance Information Manual.**
- Wire Rope Spooling.** Visually check reeving and ensure wire rope feeds on and off the drum smoothly. Verify spooling direction (overwind or underwind) is correct for winch and application.
 - Brake(s).** Lift and lower the load a short distance to test brake(s). Brake(s) must hold load without slipping. Automatic brake must release when winch control throttle is operated. If brake(s) do not hold load or do not release properly, they must be adjusted or repaired.

- Worn or improperly functioning brakes may cause excessive heat buildup and sparks.**
- Lubrication.** Refer to "LUBRICATION" on page 8 for recommended procedures and lubricants.
 - Emergency Stop.** Standard on all CE winch models. Run winch and activate emergency stop. Winch operation must stop quickly. Ensure valve resets properly.
 - Labels and Tags.** check for presence and legibility of labels. Refer to Product Parts Information Manual for correct labels and placement. Replace if damaged or missing.

Winches Not in Regular Use

- Equipment which has been idle for a period of one month or more, but less than six months, shall be given an inspection conforming to the requirements of 'Frequent Inspection' on page 8 before being placed in service.
- Equipment which has been idle for a period of over six months shall be given a complete inspection conforming with the requirements of 'Periodic Inspection' before being placed in service. Refer to Product Maintenance Information Manual.
- Standby equipment shall be inspected at least semi-annually in accordance with the requirements of 'Frequent Inspection' on page 8.
- All oils must be drained and replaced with new, and all grease cavities shall be packed to the prescribed limit. Refer to "LUBRICATION" section on page 8. Product must be operated for at least 15 seconds in both directions with well lubricated, dry air.

Storing the Winch

- Always store the winch in a no load condition.
- Wipe off all dirt and water.
- To prevent rust buildup from internal condensation, open lubricator to allow more oil into winch and operate with no load. If winch is being stored from air source place small amount of 20 weight oil at air inlet port.
- Oil the wire rope.
- Place in a dry location.
- Before returning winch to service, follow instructions for 'Winches Not In Regular Use' in the "INSPECTION" section on page 7.
- Mufflers and Breathers.** All mufflers and breathers must be removed and replaced with threaded plugs to prevent dust and moisture from entering motor and valve assemblies.
- Rotary Limit Switch.** Product equipped with a rotary limit switch must be stored with the limit switch not activated.
- Drum Brake.** Product equipped with a manual band brake must be stored with the brake in its disengaged position.
- Drum Lock.** Product equipped with a drum lock must be stored with drum locking pin in its disengaged position (i.e., not inserted into outboard drum flange).

LUBRICATION

To ensure continued satisfactory operation of winch, all points requiring lubrication must be serviced with correct lubricant at proper time interval as indicated for each assembly.

Refer to 'Maintenance Interval' chart in Product Maintenance Information Manual for recommended lubrication intervals. Use only those lubricants recommended. Other lubricants may affect product performance. Approval for use of other lubricants must be obtained from your **Ingersoll Rand** distributor. Failure to observe this precaution may result in damage to winch and/or its associated components.

Table 8: Lubrication Intervals

Component	Interval
Check Air Line Lubricator	Daily
Check Motor Oil Level	
Check Reduction and Disc Brake Oil	3 Months
Change Motor Oil	1 Year or 1,000 Hours of Product Operation
Change Gearbox Oil	
Change Disc Brake Oil	

General Lubrication

Correct lubrication is one of the most important factors in maintaining efficient product operation.

- The recommended grade of oil must be used at all times. Use of unsuitable oil may result in excessive temperature rise, loss of efficiency and possible damage to lubricated components. Refer to 'Recommended Lubricants' section on page 8.
- It is recommend that the first oil change be done after approximately 50 hours of initial operation. Thereafter, drain and replace oil according to Table 8 'Lubrication Intervals' on page 8.

- Always inspect removed oil for evidence of internal damage or contamination (metal shavings, dirt, water, etc.). If indications of damage are noted, investigate and correct before returning winch to service.
- After product operation, allow oil to settle before topping off.
- Always collect lubricants in suitable containers and dispose of in an environmentally safe manner.



WARNING

- Pneumatic products use oil to prevent excessive heat buildup and to prevent wear that could cause sparks. Oil levels must be properly maintained.**

Recommended Lubricants

Table 9: Reduction Gear and Disc Brake Recommended Lubricant Grade

Temperature	Grade Type
Below 32° F (0° C)	2 EP (ISO VG 68)
32° to 80° F (0° to 27° C)	3 EP (ISO VG 100) *
Above 80° F (27° C)	4 EP (ISO VG 150)

* Units are shipped from factory with 3 EP (ISO VG 100) lubricant.

Table 10: Air Motor Recommended Lubricant Grade

Temperature	Grade Type
Below 32° F (0° C)	ISO VG 32 (SAE 10W)
32° to 80° F (0° to 27° C)	ISO VG 68 (SAE 20W) *
Above 80° F (27° C)	ISO VG 100 (SAE 30W)

* Units are shipped from factory with ISO VG 68 (SAE 20W) lubricant.

Table 11: Recommended Grease Grade

Temperature	Grade Type
-20° to 50° F (-30° to 10° C)	EP 1 multipurpose lithium based grease
30° to 120° F (-1° to 49° C)	EP 2 multipurpose lithium based grease

■ **Motor Assembly**

Refer to Dwg. MHP2126 on page 12, **A.** Fill Cap; **B.** Vent Cap; **C.** Drain Plug; **D.** Level Plug.



- **Do not use synthetic or detergent lubricants in air motor. Synthetic lubricants will result in oil blowing by piston rings.**

The motor is splash lubricated by oil in motor housing and has no other means of lubrication. It is therefore important to use only good quality, non-detergent motor oil to ensure maximum performance and minimum downtime for repairs. Refer to 'Recommended Lubricants' section on page 8.

Add oil through filler opening until oil flows from level plug hole. Add oil slowly to prevent spilling. Refer to Table 12 'Motor Oil Capacity' on page 9.

The motor should be level-checked daily or at the start of each shift after any accumulated water has been drained off. When motors are operated in temperatures below freezing, wait long enough at the end of shift for water to separate from oil but not long enough for it to freeze. Drain water then refill to level plug, located on side of motor housing. If desired, all oil may be drained at end of shift and motor refilled with new oil.

Table 12: Motor Oil Capacity

Capacity	
quarts	litres
3	2.8

■ **Reduction Gear Assembly**

Refer to Dwg. MHP0140 on page 12, **A.** Fill Plug Position; **B.** Drum; **C.** Reduction Gear Assembly; **D.** Inboard Upright; **E.** Level Plug Position. The reduction gear is filled to the correct levels prior to shipment from the factory. Check oil level before initial winch operation. This component is splash lubricated by oil in the housing and has no other means of lubrication. It is therefore important to use high quality Extreme Pressure (EP) rust and oxidation inhibited gear oil to ensure maximum performance and minimum down time for repair.



- **Do not over fill. Excess oil will reduce operating efficiency and increase oil temperature.**
- **Only use synthetic lubricant in reduction gear.**

To ensure correct performance, highest efficiency and long life, it is essential that lubricating oil be maintained at correct level. Rotate drum until fill plug is located at top dead center then add oil up to level plug hole. Refer to Table 13 'Reduction Gear and Disc Brake Capacities' on page 9 for capacities.

■ **Disc Brake Assembly**



- **Do not attempt to lubricate disc brake with grease. The breather plug on top of the brake housing must not be used as a grease fitting.**
- **Only use synthetic lubricant in disc brake.**

Refer to Dwg. MHP1348 on page 11, **A.** Breather Plug; **B.** Drain Plug; **C.** Level Plug. The friction plates and drive plates are in a self contained oil bath and have no other means of lubrication. After an oil change or winch overhaul remove the breather plug and pour a small amount of oil through breather hole in brake housing. Allow oil to fully settle between fillings. Refer to Table 13 'Reduction Gear and Disc Brake Capacities' on page 9.



- **If too much oil is added excess oil will be discharged through breather plug when control valve is actuated.**

Table 13: Reduction Gear and Disc Brake Capacities

Model	Capacity			
	Reduction Gear		Disc Brake	
	quarts	litres	ounces	litres
FA10i	5	4.8	4 to 6	0.2

■ **Band Brake Handle**

Lubricate grease fitting monthly 3 or 4 times with 2 to 3 pumps of a grease gun. Refer to 'Recommended Lubricants' on page 8.

■ **Seals and Bearings**

If product is disassembled, clean all parts thoroughly and coat bearings and seals with clean grease. Refer to 'Recommended Lubricants' section on page 8. Use sufficient grease to provide a good protective coat. Lubricate grease fittings monthly with 2 or 3 pumps of a grease gun.

■ **Drum Locking Pin (optional feature)**

Refer to Dwg. MHP2675. Lubricate at least once every month, depending on environment and duty cycle, through grease fitting located in housing with 2 or 3 pumps of grease gun. If drum locking pin is disassembled, clean all parts thoroughly and coat with clean grease. Refer to 'Recommended Lubricants' on page 8. Use sufficient grease to provide a good protective coat.

Lubrication will help to prevent rust and allow easier locking pin operation.

■ **Wire Rope**

Follow the wire rope manufacturer's instructions. At a minimum, observe the following guidelines.

1. Clean with a brush or steam to remove dirt, rock dust or other foreign material on the surface of the wire rope.



- **Do NOT use an acid-based solvent. Only use cleaning fluids specified by the wire rope manufacturer.**
2. Apply a wire rope lubricant.
 3. Brush, drip or spray lubricant weekly, or more frequently, depending on severity of service.

PRODUCT INFORMATION GRAPHICS

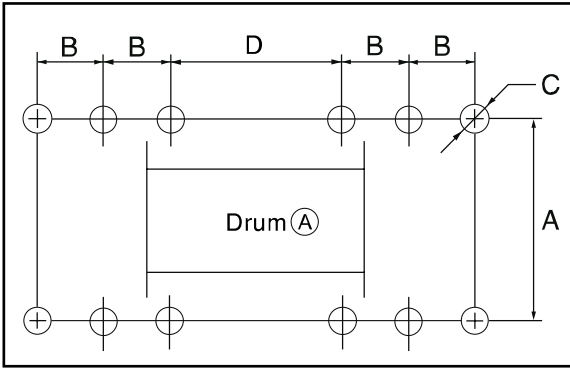

(Dwg. MHP0920)

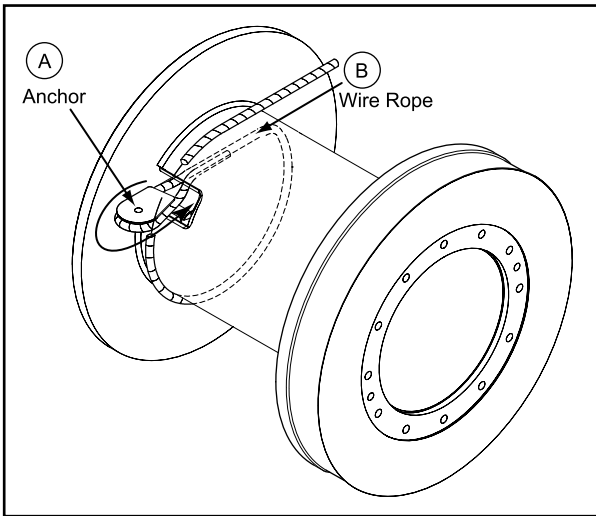

(Dwg. MHP2686)

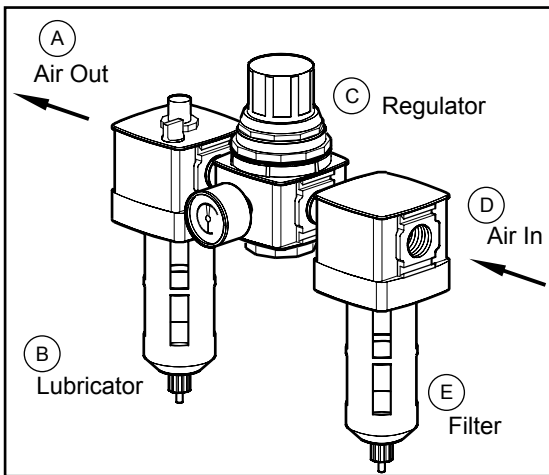

(Dwg. MHP0191)

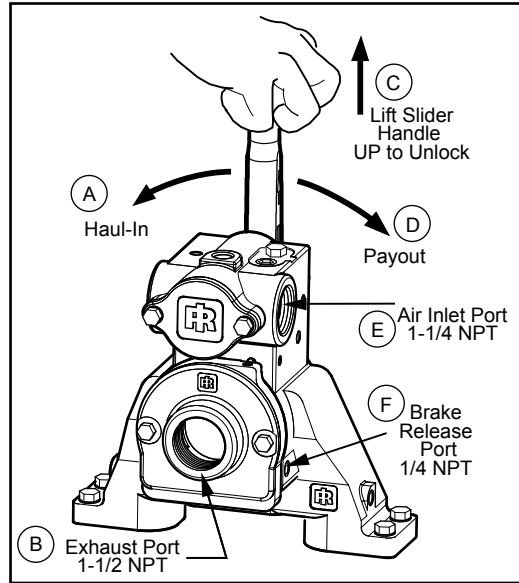

(Dwg. MHP1809)

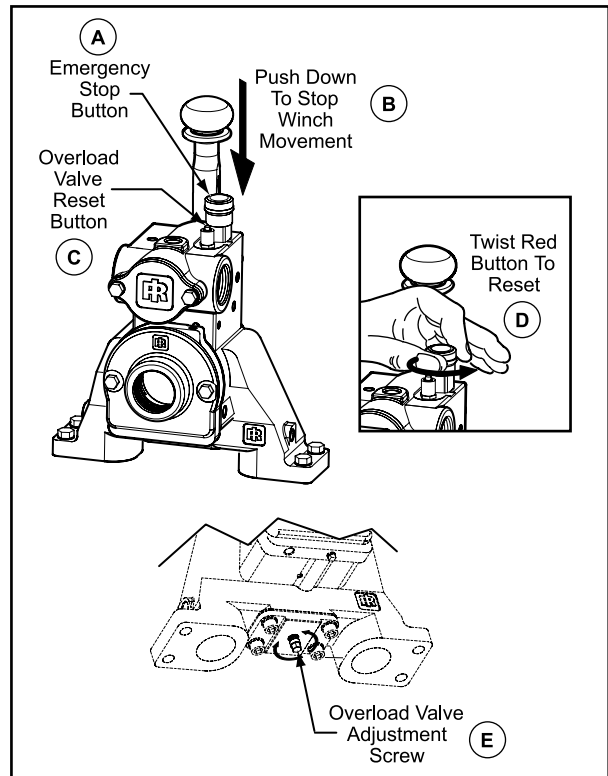

(Dwg. MHP2619)

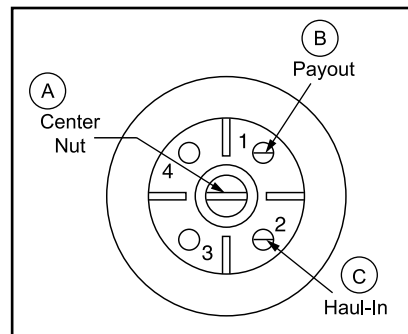

(Dwg. MHP2688)

PRODUCT INFORMATION GRAPHICS (CONTINUED)

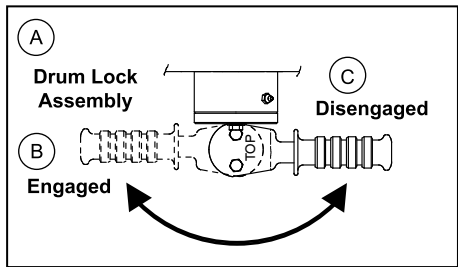

(Dwg. MHP2772)

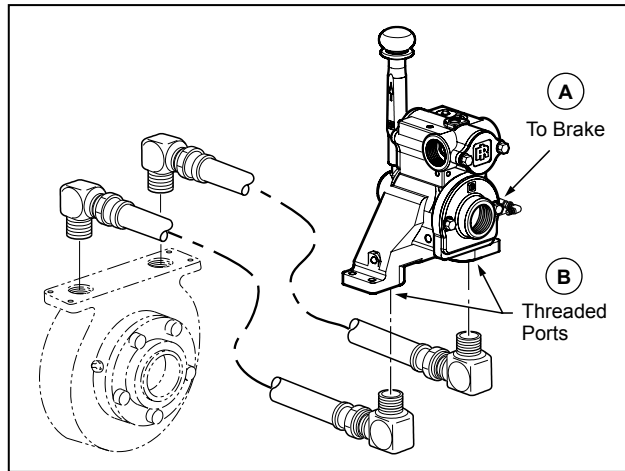

(Dwg. MHP2043)

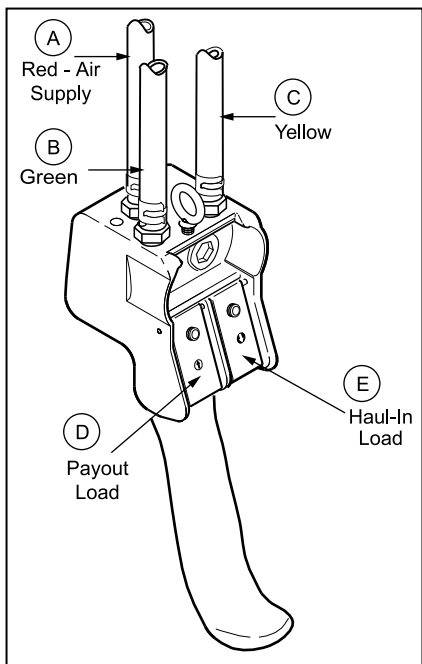

(Dwg. MHP2398)

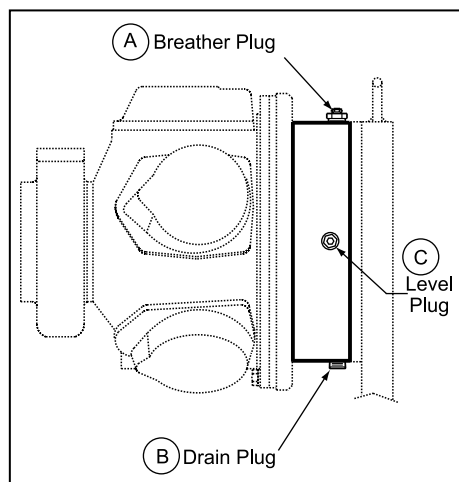

(Dwg. MHP1348)

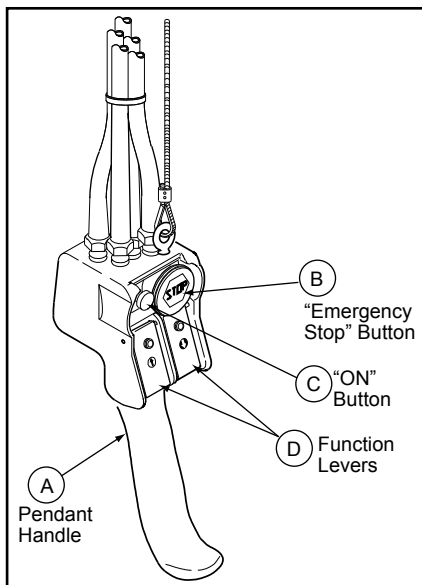

(Dwg. MHP1892)

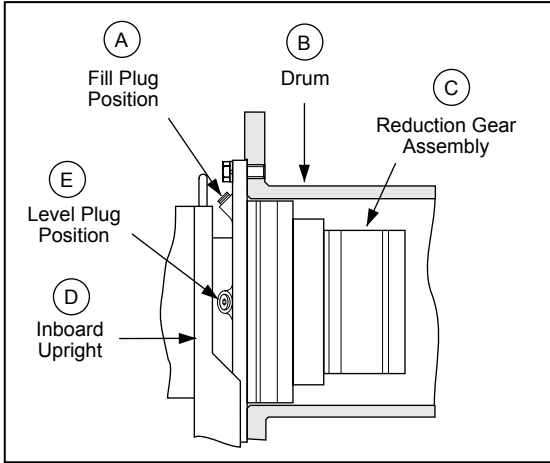

PRODUCT INFORMATION GRAPHICS (CONTINUED)

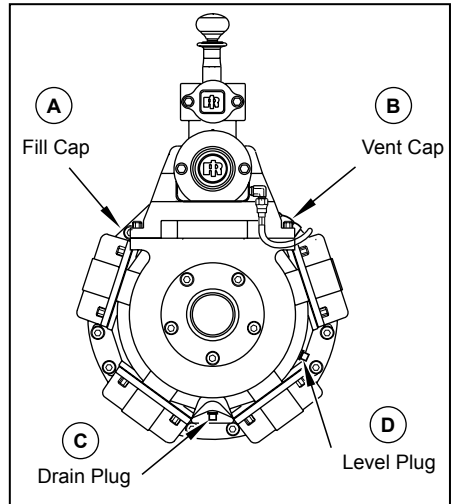

(Dwg. MHP0140)



(Dwg. MHP2126)

DECLARATION OF CONFORMITY	
CE	(CS) PROHLÁŠENÍ O SHODĚ (DA) OVERENSSTEMMELSESERKLÆRING (DE) KONFORMITÄTSESKLÄRUNG (EL) ΔΗΛΩΣΗ ΑΝΑΓΝΩΡΙΣΗΣ (ES) DECLARACIÓN DE CONFORMIDAD (FI) VAKUUTUS NORMIEN TÄYTTÄMISESTÄ (FR) CERTIFICAT DE CONFORMITÉ (HU) MEGFELELŐSÉGI NYILATKOZAT (IT) DICHIARAZIONE DI CONFORMITÀ (LT) ATITIKTIES DEKLARACIJA (LV) ATBILSTĪBAS DEKLARĀCIJA (NL) SCHRIFTELIJKE VERKLARING VAN CONFORMITEIT (NO) KONFORMITETSERKLÆRING (PT) DECLARAÇÃO DE CONFORMIDADE (PL) DEKLARACJA ZGODNOŚCI (SK) PREHLÁSENIE O ZHODE (SL) IZJAVA O SKLADNOSTI (SV) FÖRSÄKRAN OM ÖVERENSSTÄMMELSE
Ingersoll Rand	529, Avenue Roger Salengro, 59450 Sin Le Noble, France
Declare under our sole responsibility that the product: Pneumatic Winches	
<p>(CS) Prohlašujeme na svou zodpovědnost, že produkt: Pneumatický kladkostroj (DA) Erklærer som eneansvarlig, at nedenstående produkt: Pneumatisk lift (DE) Erklären hiermit, gemäß unserer alleinigen Verantwortung, daß die Geräte: Druckluft-Kettenzug (EL) Δηλώνουμε ότι με δική μας ευθύνη το προϊόν: Πνευματικός ανυψωτήρας (ES) Declaramos que, bajo nuestra responsabilidad exclusiva, el producto: Polipasto neumático (FI) Vakuutamme ja kannamme yksin täyden vastuun siitä, että tuote: Paineilmanostin (FR) Déclarons sous notre seule responsabilité que le produit: Palans pneumatiques (HU) Kizárólagos felelősségünk tudatában kijelentjük, hogy a termék: Pneumatikus emelő (IT) Dichiariamo sotto la nostra unica responsabilità che il prodotto: Paranco pneumatico (LT) Deklarėjam tikai uz musu atbildību, ka šis ražojums: Pneumatiniai suktuvai (LV) Prisiimdami visā atsakomybē pareidkiamē, kad gaminys: Pneimatiskāš vinčas (NL) Verklaren, onder onze uitsluitende aansprakelijkheid, dat het product: Pneumatische takel (NO) Erklærer på ære og samvittighet at produktet: Pneumatiske vinsjer (PT) Declaramos sob a nossa exclusiva responsabilidade que o produto: Guinchos Pneumáticos (PL) Przyjmując pełną odpowiedzialność, oświadczamy, że produkt: Wciągnik pneumatyczny (SK) Závazne prehlasujeme, že výrobok: pneumatický kladkostroj (SL) Pod polno odgovornostjo izjavljamo, da je izdelek: Pnevmatško dvigalo (SV) Intyggar enligt vårt ansvar att produkten: Tryckluftsdrivna lyftdon</p>	
Model: FA10i-CE / Serial Number Range: A02737 and up	
<p>(CS) Model: / Rozsah výrobních čísel: (DA) Model: / Seriennummerområde: (DE) Modell: / Seriennummernbereich: (EL) Μοντέλο: / Κλίμακα σειριακών αριθμών: (ES) Modelo: / Números de serie: (FI) Malli: / Sarjanumeroalue: (FR) Modèle: / Gamme de numéros de série: (HU) Modell: / Gyártási szám-tartomány: (IT) Modello: / Gamma delle matricole: (LT) Modelis: / Šcrijas numuru diapazons: (LV) Modelis: / Serijos numerio eilē: (NL) Model: / Seriennummer: (NO) Modell: / Serien: (PT) Modelo: / Gama de Nos de Série: (PL) Model: / Zakres numerów serii: (SK) Model: / Rozsah výrobných čísel: (SL) Model: / Območje serijskih števil: (SV) Modell: / Seriennummer, mellan:</p>	
To which this declaration relates, is in compliance with provisions of Directive(s): 2006/42/EC (machinery), 2014/34/EU (ATEX)	
<p>(CS) Ke kterým se toto prohlášení vztahuje, odpovídají ustanovením směrnic: (DA) som denne erklæring vedrører, overholder bestemmelserne i følgende direktiv(er): (DE) auf das sich diese Erklärung bezieht, der folgenden Richtlinie entspricht: (EL) στο οποίο αναφέρεται αυτή η δήλωση, πληροί τις διατάξεις της Οδηγίας: (ES) a los que se refiere la presente declaración, cumplen con todo lo establecido en las directivas: (FI) johon tämä vakuutus viittaa, täyttää direktiiveissä: (FR) Objet de ce certificat, est conforme aux prescriptions des Directives: (HU) Amelyekre ezen nyilatkozat vonatkozik, megfelelnek a következő irányelvek előírásainak: (IT) a cui si riferisce la presente dichiarazione è conforme alle normative delle direttive: (LT) Kuriems taikoma ši deklaracija, atitinka šios direktyvos (-ų) nuostatas: (LV) Uz kuru ši deklarācija attiecas, atbilst direktīvas(u) nosacījumiem: (NL) waarop deze verklaring betrekking heeft overeenkomt met de bepalingen van directieven: (NO) som denne erklæringen gjelder for, oppfyller bestemmelsene i direktivene: (PT) Ao qual se refere a presente declaração, está de acordo com as provisões da(s) Directiva(s): (PL) Którego dotyczy niniejsza deklaracja, jest zgodny z wymogami dyrektyw: (SK) Na ktorý sa toto prehlásenie vzťahuje, je v súlade s ustanoveniami Smernice (Smernic): (SL) Na katerega se ta izjava o skladnosti nanaša, v skladu z določili smernic. (SV) Som detta intyg avser, överensstämmer med följande direktiv:</p>	
By using the following Principle Standards: ISO 12100: 2010, EN 14492-1: 2006+A1, EN 13463-1: 2009 and EN 13463-5: 2011	
<p>(CS) Použitím následujících zákonných norem: (DA) ved at være i overensstemmelse med følgende hovedstandard(er): (DE) Unter Anlehnung an die folgenden Grundnormen entsprechen: (EL) Χρησιμοποιώντας τα παρακάτω κύρια πρότυπα: (ES) conforme a los siguientes estándares: (FI) esitetty vaatimukset seuraavia perusnormeja käytettäessä: (FR) En observant les normes de principe suivantes: (HU) A következő elvi szabványok alkalmazása mellett: (IT) Seguendo i principi standard indicati di seguito: (LT) Remiantis šiais pagrindiniais standartais: (LV) Izmantojot šādus galvenos standartus: (NL) overeenkomstig de volgende hoofdstandaards: (NO) Ved å bruke følgende prinsipielle standarder: (PT) observando as seguintes Normas Principais: (PL) Spełniając wymogi następujących głównych norm: (SK) Pri dodržaní nasledovných noriem: (SL) Uporabljeni osnovni standardi: (SV) Genom att använda följande principstandard:</p>	
Date: February, 2016	
<p>(CS) Datum: Únor, 2016 (DA) Dato: Februar, 2016 (DE) Datum: Februar, 2016 (EL) Ημερομηνία: Φεβρουάριος, 2016 (ES) Fecha: Febrero, 2016 (FI) Päiväys: Helmikuu, 2016 (FR) Date: Février, 2016 (HU) Dátum: Február, 2016 (IT) Data: Febbraio, 2016 (LT) Datums: Vasaris, 2016 (LV) Datums: Februāris, 2016 (NO) Dato: Februar, 2016 (NL) Datum: Februari, 2016 (SV) Datum: Februari, 2016 (PT) Data: Fevereiro, 2016 (PL) Data: luty, 2016 (SK) Dátum: Február, 2016 (SL) Datum: februar, 2016</p>	
Approved By:  Anthony Jones Global Engineering Leader Material Handling 20017 72nd Avenue South Kent, WA 98032 USA	Secondary:  Alexis Flipo Product Engineering Manager Material Handling Douai, France

SERVICE NOTES

SERVICE NOTES
